

TWO POINT PERSPECTIVE

Full Tutorial: https://youtu.be/nTV_fWs8QUU

THAT ART
ARTIST & EDUCATOR
TEACHER

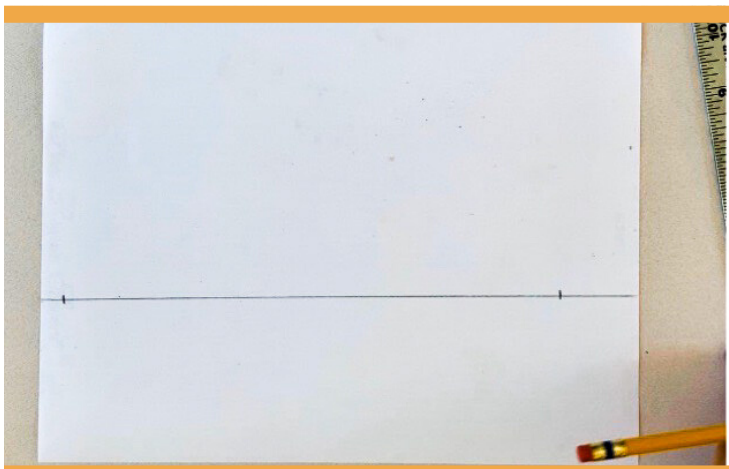

1. HORIZONTAL LINE

Use a ruler to draw a horizontal line across your paper.

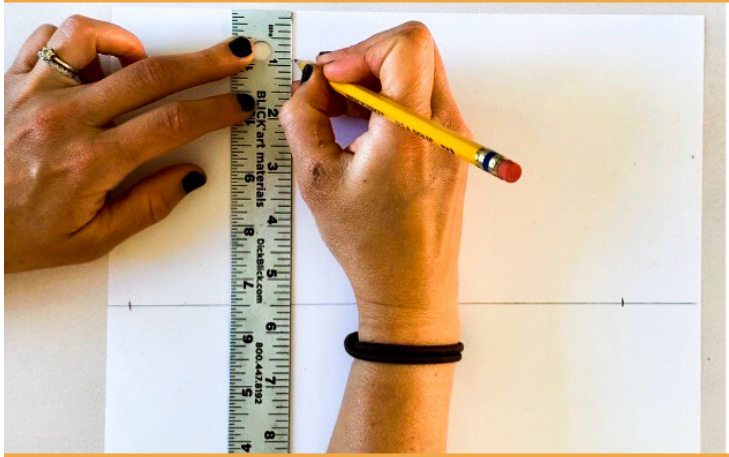

2. VANISHING POINTS

Add two dots for your vanishing points on each end of your horizon line.



3. VERTICAL LINE

Use a ruler to draw a vertical line anywhere on your paper.



4. LEFT SIDE

Use a ruler to connect the top and bottom of your vertical line to your left vanishing point.

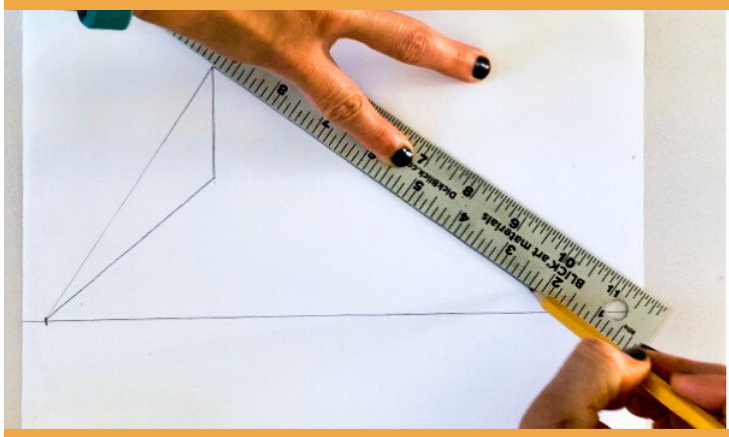

5. RIGHT SIDE

Use a ruler to connect the top and bottom of your vertical line to your right vanishing point.

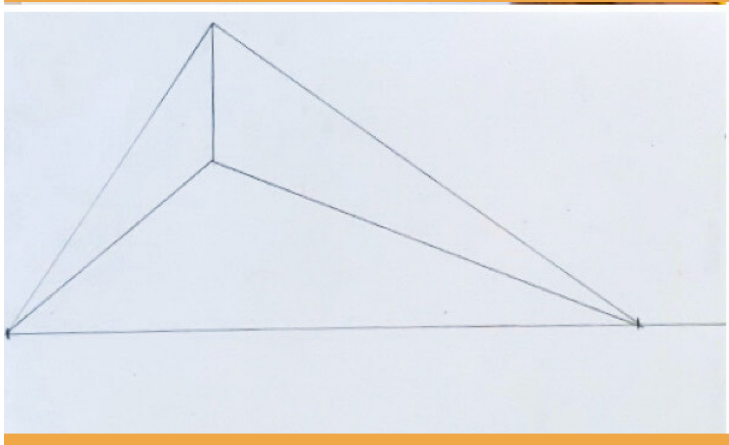

PRO TIP:

Draw the lines to each vanishing point lightly so you can erase them easier!

THAT ART
ARTIST & EDUCATOR
TEACHER

TWO POINT PERSPECTIVE

Full Tutorial: https://youtu.be/nTV_fWs8QUU

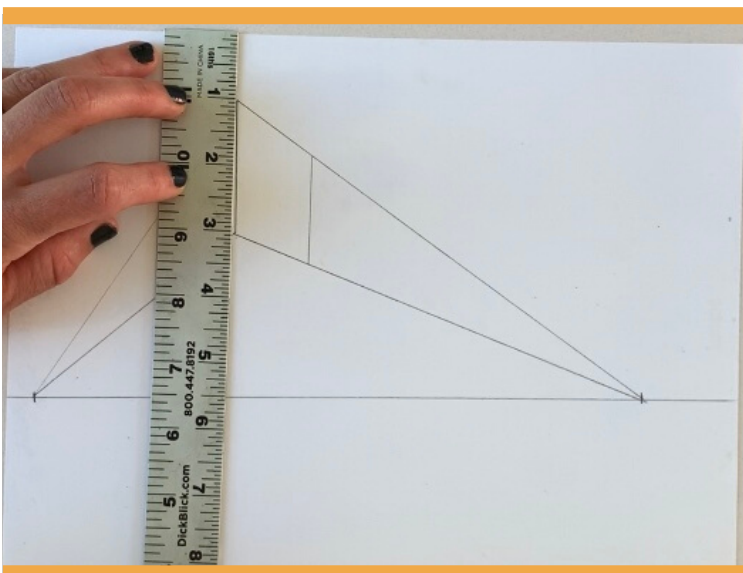

6. PARALLEL LINES

Use a ruler to crop your shape on both sides wherever you want. All three vertical lines need to be parallel.

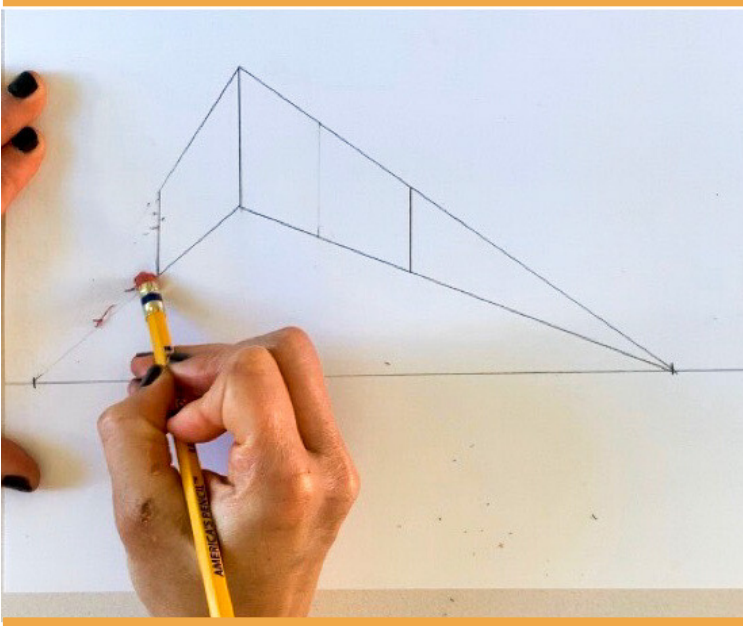

7. ERASE!

Erase the leftover lines.

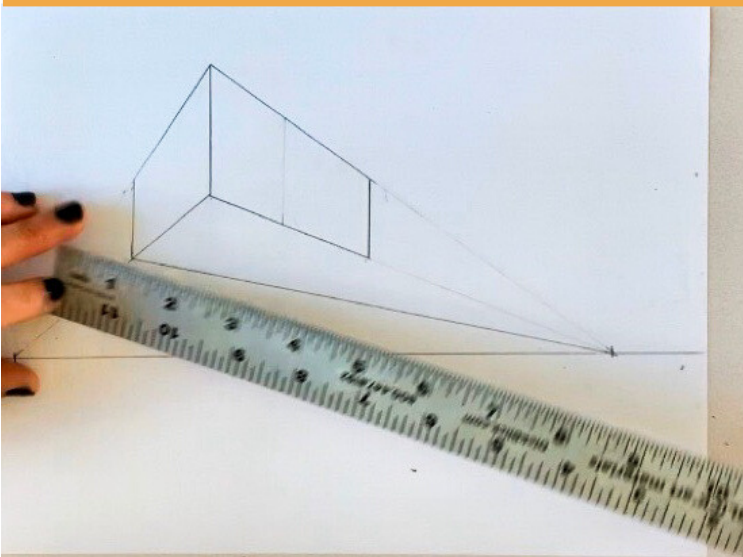

8. CRISS-CROSS LINES

To create the bottom of your shape, cross the left corner to the right vanishing point. Then, connect your right corner to your left vanishing point.

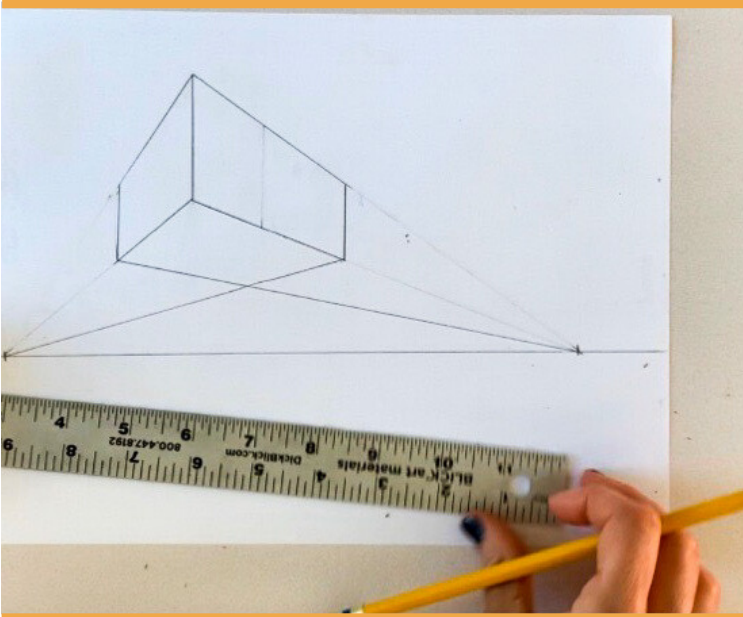

9. ERASE!

Erase the leftover lines to create your final shape!

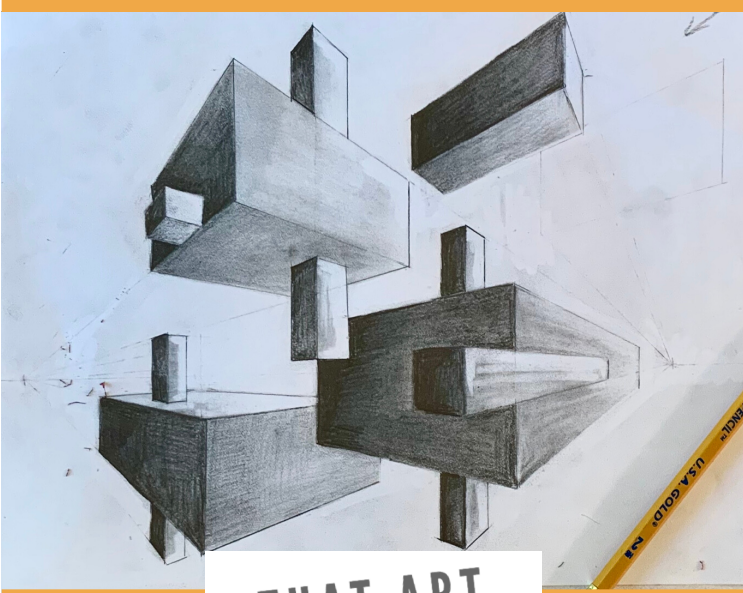

LEVEL UP!

Repeat your steps to create a landscape of flying shapes. Add overlapping shapes and shading!

Not sure how?

Let me show you!

Full tutorial:

https://youtu.be/nTV_fWs8QUU